



Chip Resistor

AR Series Precision Chip Resistors / 精密贴片电阻

► Features

- Thin Film Passivated NiCr Resistor
- Very Tight Tolerance from $\pm 0.01\% \sim \pm 1\%$
- Extremely Low TCR from $\pm 5\text{PPM}/^\circ\text{C} \sim \pm 50\text{PPM}/^\circ\text{C}$
- Wide R-Value range
- Products with Pb-free Terminations Meet RoHS Requirements

► Applications

- Medical Equipment
- Testing / Measurement instrument
- Consumer Product
- Printer Equipment
- Automatic Equipment Controller
- Converters
- Communication Device, Cell phone, GPS, PDA



► AR Resistors Construction

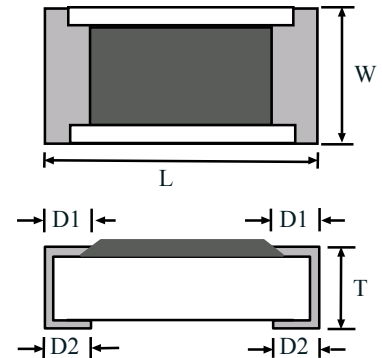
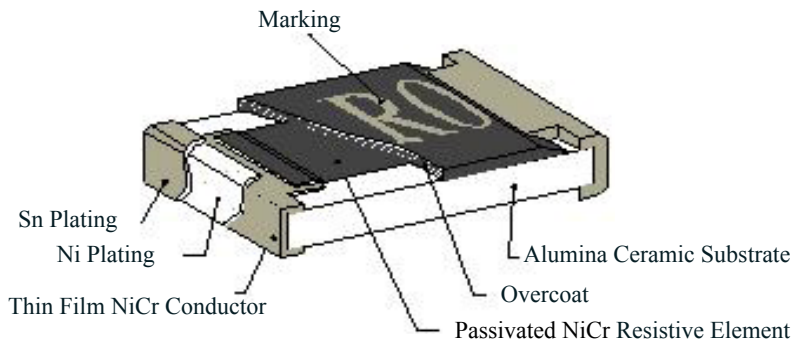

► AR Resistors Dimensions (Unit: mm)

Codes	L	W	T	D1	D2
AR02	1.00 \pm 0.05	0.50 \pm 0.05	0.30 \pm 0.05	0.20 \pm 0.10	0.20 \pm 0.10
AR03	1.55 \pm 0.10	0.80 \pm 0.10	0.45 \pm 0.10	0.30 \pm 0.20	0.30 \pm 0.20
AR05	2.00 \pm 0.15	1.25 \pm 0.15	0.55 \pm 0.10	0.30 \pm 0.20	0.40 \pm 0.25
AR06	3.05 \pm 0.15	1.55 \pm 0.15	0.55 \pm 0.10	0.42 \pm 0.20	0.35 \pm 0.25
AR10	4.90 \pm 0.15	2.40 \pm 0.15	0.55 \pm 0.10	0.60 \pm 0.30	0.50 \pm 0.25
AR12	6.30 \pm 0.15	3.10 \pm 0.15	0.55 \pm 0.10	0.60 \pm 0.30	0.50 \pm 0.25

► Standard Electrical Specifications - Precision Chip Resistor

Type	Power Rating at 70°C	Operating Temp. Range	Max Operating Voltage	Max Overloading Voltage	Resistance Tolerance ($\pm\%$)	Resistance Range	TCR ($\pm\text{PPM}/^\circ\text{C}$)
AR02 (0402)	1/16W	-55 ~ +155°C	25V	50V	0.01, 0.05, 0.1, 0.25, 0.5	50Ω~2KΩ	5
					0.01, 0.05, 0.1, 0.25, 0.5	50Ω~12KΩ	10, 15
					0.01, 0.05	50Ω~12KΩ	25, 50
					0.1, 0.25, 0.5, 1	10Ω~100KΩ	25, 50
AR03 (0603)	1/16W	-55 ~ +155°C	50V	100V	0.01, 0.05, 0.1, 0.25, 0.5	50Ω~8KΩ	5
					0.01, 0.05, 0.1, 0.25, 0.5	25Ω~100KΩ	10, 15
					0.01	25Ω~100KΩ	25, 50
					0.05	4.7Ω~150KΩ	25, 50
					0.1, 0.25, 0.5, 1	4.7Ω~402KΩ	25, 50
0.25, 0.5, 1	2Ω~4.6Ω	25, 50					

Continued on the following page. ↘





Chip Resistor

Continued from the preceding page.

Type	Power Rating at 70°C	Operating Temp. Range	Max Operating Voltage	Max Overloading Voltage	Resistance Tolerance (±%)	Resistance Range	TCR (±PPM/°C)
AR05 (0805)	1/10W	-55 ~+155°C	100V	200V	0.01, 0.05, 0.1, 0.25, 0.5	50Ω~16KΩ	5
					0.01, 0.05, 0.1, 0.25, 0.5	25Ω~200KΩ	10, 15
					0.01	25Ω~200KΩ	25, 50
					0.05	4.7Ω~500KΩ	25, 50
					0.1, 0.25, 0.5, 1	4.7Ω~1MΩ	25, 50
					0.25, 0.5, 1	1Ω~4.6Ω	25, 50
AR06 (1206)	1/8W	-55 ~+155°C	150V	300V	0.01, 0.05, 0.1, 0.25, 0.5	50Ω~30KΩ	5
					0.01, 0.05, 0.1, 0.25, 0.5	25Ω~500KΩ	10, 15
					0.01	25Ω~500KΩ	25, 50
					0.05	4.7Ω~1MΩ	25, 50
					0.1, 0.25, 0.5, 1	4.7Ω~1MΩ	25, 50
					0.25, 0.5, 1	1Ω~4.6Ω, 1MΩ~2MΩ	25, 50
AR10 (2010)	1/4W	-55 ~+155°C	150V	300V	0.01, 0.05, 0.1, 0.25, 0.5	50Ω~30KΩ	5
					0.01, 0.05, 0.1, 0.25, 0.5	25Ω~500KΩ	10, 15
					0.01	25Ω~500KΩ	25, 50
					0.05	4.7Ω~1MΩ	25, 50
					0.1, 0.25, 0.5, 1	4.7Ω~1MΩ	25, 50
					0.25, 0.5, 1	1Ω~4.6Ω, 1MΩ~2MΩ	25, 50
AR12 (2512)	1/2W	-55 ~+155°C	150V	300V	0.01, 0.05, 0.1, 0.25, 0.5	50Ω~50KΩ	5
					0.01, 0.05, 0.1, 0.25, 0.5	25Ω~500KΩ	10, 15
					0.01	25Ω~500KΩ	25, 50
					0.05	4.7Ω~1MΩ	25, 50
					0.1, 0.25, 0.5, 1	4.7Ω~1MΩ	25, 50
					0.25, 0.5, 1	1Ω~4.6Ω, 1MΩ~2MΩ	25, 50

▶ AR Resistors Higher Power Rating Electrical Specifications

Type	Power Rating at 70°C	Operating Temp. Range	Max Operating Voltage	Max Overloading Voltage	Resistance Tolerance (±%)	Resistance Range	TCR (±PPM/°C)
AR03 (0603)	1/10W	-55 ~+155°C	50V	100V	0.10, 0.25, 0.50	10Ω~332KΩ	25, 50
AR05 (0805)	1/8W	-55 ~+155°C	150V	300V	0.10, 0.25, 0.50	4.7Ω~1MΩ	25, 50
AR06 (1206)	1/4W	-55 ~+155°C	200V	400V	0.10, 0.25, 0.50	4.7Ω~1MΩ	25, 50

• Token has the ability to manufacture above options based on customer's requirement.





Chip Resistor

► Recommend Land Pattern (Unit: mm)

Codes	A	B	C
AR12	4.90	1.60	3.10±0.2
AR10	3.60	1.40	2.50±0.2
AR06	2.00	1.15	1.70±0.2
AR05	1.00	1.00	1.35±0.2
AR03	0.80	1.00	0.90±0.2
AR02	0.50	0.50	0.60±0.2

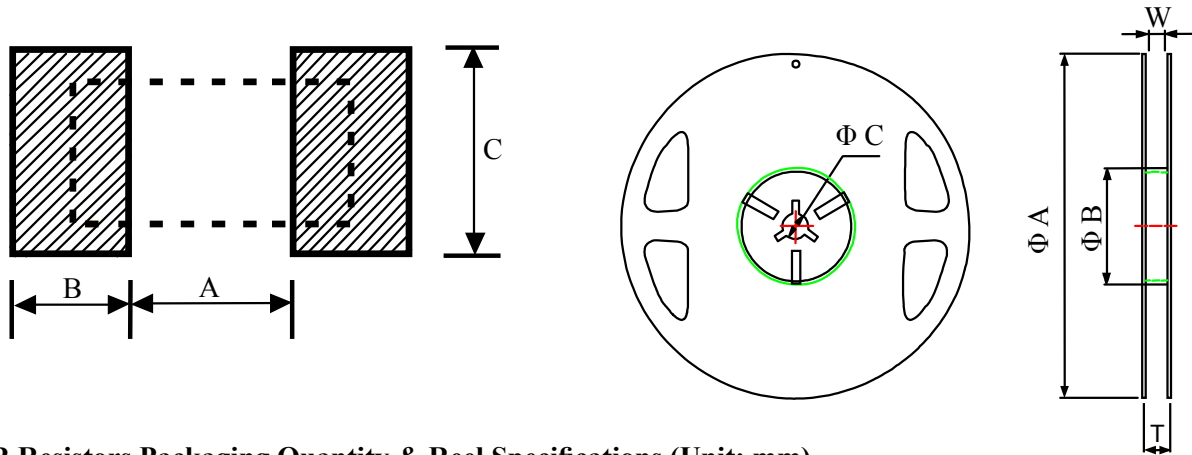

► AR Resistors Packaging Quantity & Reel Specifications (Unit: mm)

Codes	ΦA	ΦB	ΦC	W	T	Paper Tape (PCS)	Emboss Plastic Tape (PCS)
AR02	178±1	60.0±0.5	13.0±0.20	9.00±0.50	12.0±0.15	10,000	-
AR03	178±1	60.0±0.5	13.0±0.20	9.00±0.50	12.0±0.15	5,000	-
AR05	178±1	60.0±0.5	13.0±0.20	9.00±0.50	12.0±0.15	5,000	-
AR06	178±1	60.0±0.5	13.0±0.20	9.00±0.50	12.0±0.15	5,000	-
AR10	178±1	60.2±0.5	13.0±1.00	13.2±1.50	16.0±0.20	-	4,000
AR12	178±1	60.2±0.5	13.0±0.50	13.2±1.50	16.0±0.20	-	4,000

► AR Resistors Paper Tape Specifications (Unit: mm)

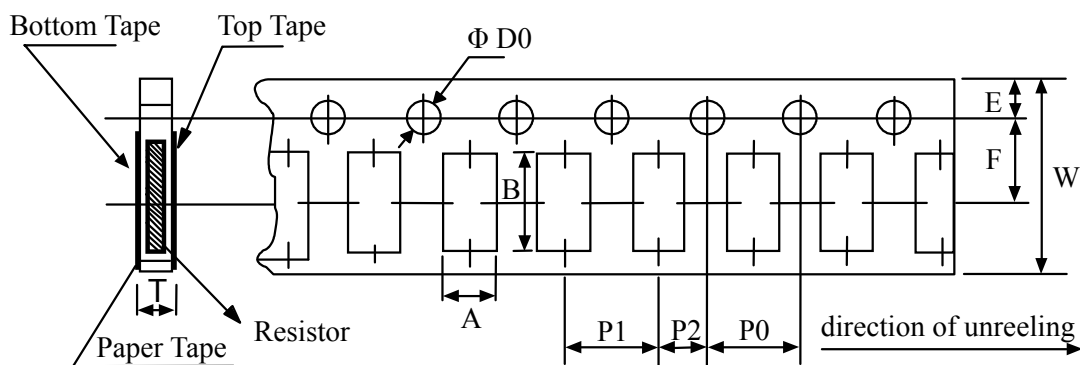

Codes	A	B	W	E	F	P0	P1	P2	ΦD0	T
AR02	0.70±0.05	1.16±0.05	8.00±0.10	1.75±0.05	3.5±0.05	4.00±0.10	2.00±0.05	2.00±0.05	1.55±0.05	0.40±0.03
AR03	1.10±0.05	1.90±0.05	8.00±0.10	1.75±0.05	3.5±0.05	4.00±0.10	4.00±0.10	2.00±0.05	1.55±0.05	0.60±0.03
AR05	1.60±0.05	2.37±0.05	8.00±0.10	1.75±0.05	3.5±0.05	4.00±0.10	4.00±0.10	2.00±0.05	1.55±0.05	0.75±0.05
AR06	2.00±0.05	3.55±0.05	8.00±0.10	1.75±0.05	3.5±0.05	4.00±0.10	4.00±0.10	2.00±0.05	1.55±0.05	0.75±0.05



Chip Resistor

► Emboss Plastic Tape Specifications (Unit: mm)

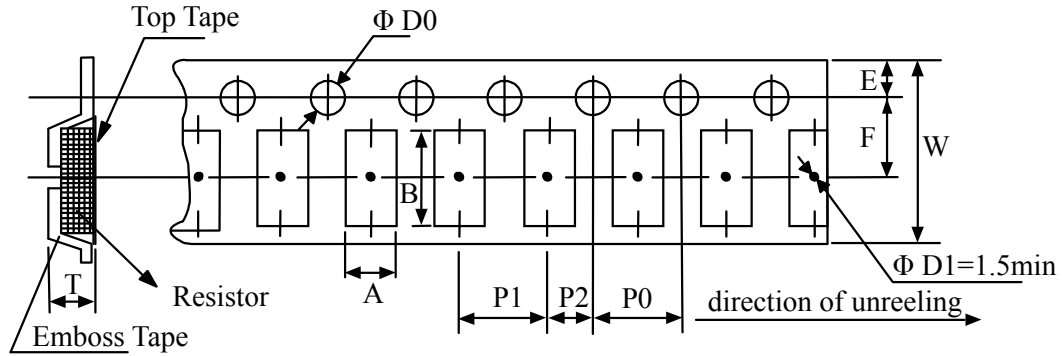

Codes	A	B	W	E	F	P0	P1	P2	$\Phi D0$	T
AR10	2.85±0.10	5.45±0.10	12.0±0.10	1.75±0.10	5.5±0.05	4.00±0.05	4.00±0.10	2.00±0.05	1.50±0.10	1.00±0.20
AR12	3.40±0.10	6.65±0.10	12.0±0.10	1.75±0.10	5.5±0.05	4.00±0.05	4.00±0.10	2.00±0.05	1.50±0.10	1.00±0.20

► AR Resistors Derating Curve

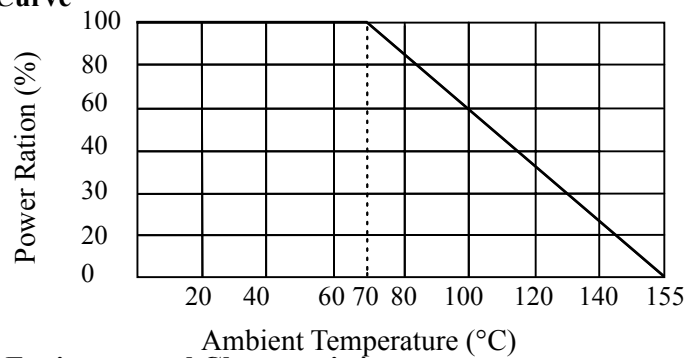

► Precision Chip Resistor Environmental Characteristics

Item	Specification		Test Method
	Tol.≤0.05%	Tol.>0.05%	
Temperature Coefficient of Resistance	AS Spec		MIL-STD-202F Method 304 +25/-55/+25/+125/+25°C
Short Time Overload	$\Delta R \pm 0.05\%$	$\Delta R \pm 0.5\%$	JIS-C-5202-5.5
	$\Delta R \pm 0.5\%$ for high power rating		RCWV*2.5 or Max Overloading Voltage , 5 seconds.
Dielectric Withstand Voltage	By type		MIL-STD-202F Method 301 Apply Max Overload Voltage for 1 minute
Insulation Resistance	>1000M Ω		MIL-STD-202F Method 302 Apply 100VDC for 1minute
Thermal Shock	$\Delta R \pm 0.05\%$	$\Delta R \pm 0.25\%$	MIL-STD-202F Method 107G -55°C~150°C, 100cycles
Load Life	$\Delta R \pm 0.05\%$	$\Delta R \pm 0.2\%$	MIL-STD-202F Method 108A RCWV, 70°C, 1.5 hours ON, 0.5 hours OFF, 1000~1048 hours
	>7K Ω $\Delta R \pm 0.5\%$		
	$\Delta R \pm 0.5\%$ for high power rating		
humidity (Steady State)	$\Delta R \pm 0.05\%$	$\Delta R \pm 0.3\%$	MIL-STD-202F Method 103B 40°C, 90~95%RH, RCWV 1.5 hours ON, 0.5 hours OFF, total 1000~1048 hours
	$\Delta R \pm 0.5\%$ for high power rating		
Resistance to dry heat	$\Delta R \pm 0.05\%$	$\Delta R \pm 0.2\%$	JIS-C-5202-7.2 96 hours @ +155°C without load
Low Temperature Operation	$\Delta R \pm 0.05\%$	$\Delta R \pm 0.2\%$	JIS-C-5202-7.1
	$\Delta R \pm 0.5\%$ for high power rating		1hour, -65°C, followed by 45minutes of RCWV
Bending Strength	$\Delta R \pm 0.05\%$	$\Delta R \pm 0.2\%$	JIS-C-5202-6.1.4 Bending Amplitude 3mm for 10seconds
Solderability	95%min coverage		MIL-STD-202F Method 208H; 260°C±5°C, 2±0.5(sec)
Resistance to Soldering Heat	$\Delta R \pm 0.05\%$	$\Delta R \pm 0.2\%$	MIL-STD-202F Method 210E; 260±5°C, 10±1 second

Remark: Storage Temperature: 25±3°C; Humidity < 80%RH



Chip Resistor

How to Order

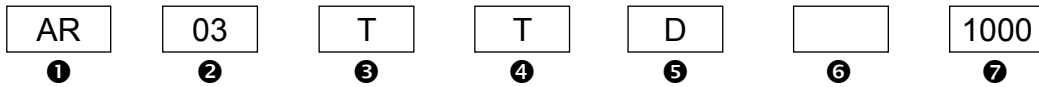

① Product Type

② Dimensions(L×W)

Code	Dimensions(L×W)
02	1.00×0.50mm
03	1.60×0.80mm
05	2.00×1.25mm
06	3.00×1.50mm
10	4.90×2.40mm
12	6.30×3.10mm

③ Resistance Tolerance

Code	Resistance Tolerance
T	±0.01%
B	±0.10%
C	±0.25%
D	±0.50%
F	±1.00%

④ Packaging

Code	Packaging
T	Taping Reel
P	Bulk

⑤ TCR

Code	TCR
S	±5ppm /°C
B	±10ppm /°C
N	±15ppm /°C
C	±25ppm /°C
D	±50ppm /°C

⑥ Higher Power Rating

Code	Power Rating
	Standard / Special
V	1/4W
W	1/8W
X	1/10W

⑦ Resistance

Code	Resistance
1000	100Ω
2201	2200Ω
1002	10000Ω
4992	49900Ω
1003	100000Ω